

# S-L Hyspeed

## DOUBLE ACTION LEVER WINDLASS

Installation,  
Operation  
and  
Maintenance  
Instructions



### CONTENTS

#### 1. PARTS

- 1.1 Exploded Diagram
- 1.2 For Future Reference
- 1.3 Parts List

#### 2. SPECIFICATION

- 2.1 Gipsy Suitability
- 2.2 Performance
- 2.3 Materials
- 2.4 Package Contents

#### 3. ACCESSORIES & SPARES KITS

#### 4. PLANNING THE INSTALLATION

- 5. INSTALLATION
- 5.1 Fitting Windlass to Deck
- 5.2 Joining Rope to Chain

#### 6. OPERATING INSTRUCTIONS

- 6.1 Safety First!
- 6.2 Function of Clutch
- 6.3 Function of Gipsy Pawl
- 6.4 Hauling In
- 6.5 Lying to Anchor
- 6.6 Anchor recovery
- 6.7 Warping
- 6.8 Operating Tips

#### 7. IMPORTANT USER INFORMATION

- 8. MAINTENANCE
- 8.1 General Recommendations
- 8.2 Winter Laying Up

#### 9. WARRANTY

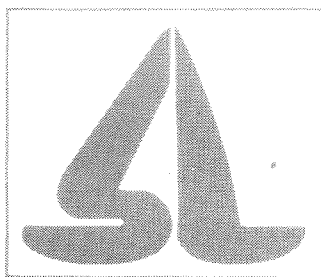

**SIMPSON  
LAWRENCE**

# 1. PARTS

## 1.1 Exploded Diagram

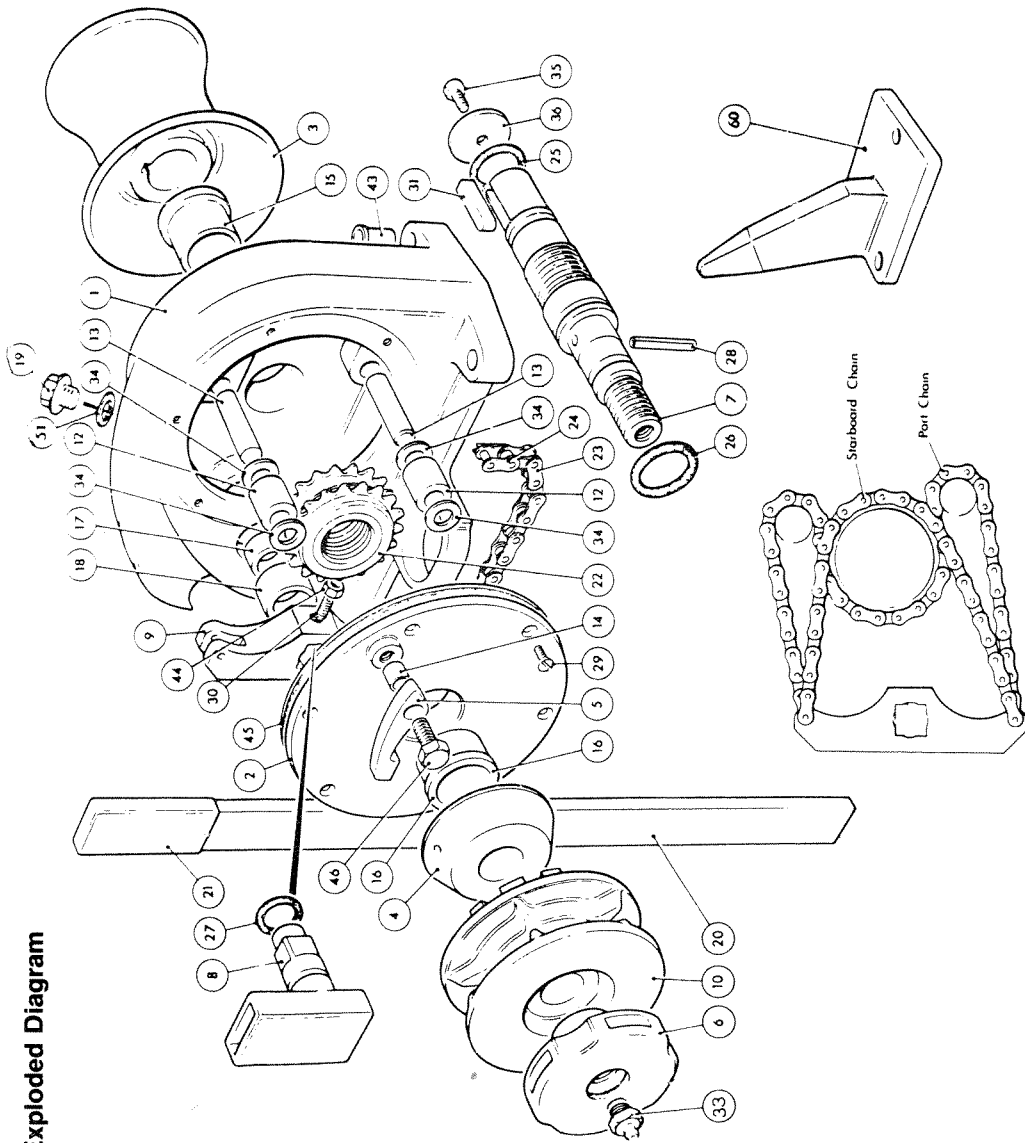

NOTE:— When ordering Spares, please quote Serial Number which is stamped on the upper face of the base flange

### 1.2 For Future Reference

After you have read this instruction booklet, please keep it safe on board your vessel for future reference.

1.2.2 Please note your serial number, which is stamped on the upper face of the base flange.

1.2.1 Identify your model

| Type                 | Gipsy                | Drum               | List No. | Tick |
|----------------------|----------------------|--------------------|----------|------|
| Standard             | Galvanised Cast Iron | Anodised Aluminium | 0051000  |      |
| Standard, Rope/Chain | Bronze               | Anodised Aluminium | 0051090  |      |
| Hi-spec, Rope/Chain  | Chrome Plated        | Chrome Plated      | 0051095  |      |
| Gipsy                | Bronze               | Bronze             |          |      |

The above information is essential when ordering spare parts.

## 1.3 PARTS LIST

| Item No. | List No. | Description        | Quantity |
|----------|----------|--------------------|----------|
| 1        |          | Case               | 1        |
| 2        |          | Cover              | 1        |
| 3        |          | Drum               | 1        |
| 4        |          | Clutch Cone        | 1        |
| 5        |          | Pawl               | 1        |
| 6        |          | Clutch Nut         | 1        |
| 7        |          | Mainshaft          | 1        |
| 8        |          | Operating Spindle  | 1        |
| 9        |          | Operating Lever    | 1        |
| 10       |          | Gipsy              | 1        |
| 12       |          | Roller             | 2        |
| 13       |          | Roller Spindle     | 2        |
| 14       |          | Spacer             | 1        |
| 15       |          | Bush, Port         | 1        |
| 16       |          | Bush, Starboard    | 1        |
| 17       |          | Bush, Port         | 1        |
| 18       |          | Bush, Starboard    | 1        |
| 19       |          | Plug               | 1        |
| 20       |          | Handle             | 1        |
| 21       |          | Handle Grip        | 1        |
| 22       |          | Freewheel Sprocket | 2        |
| 23       |          | Roller Chain       | 1 Set    |
| 24       |          | Spring Link        | 4        |
| 25       |          | O Ring             | 1        |
| 26       |          | O Ring             | 1        |
| 27       |          | O Ring             | 1        |
| 28       |          | Spring Pin         | 1        |
| 29       |          | Screw              | 6        |
| 30       |          | Screw              | 1        |
| 31       |          | Key                | 1        |
| 33       |          | Grease Nipple      | 1        |
| 34       |          | Washer             | 4        |
| 35       |          | Set                | 1        |
| 36       |          | Washer             | 1        |
| 43       |          | Headed Bush        | 4        |
| 44       |          | Full Nut           | 1        |
| 45       |          | Gasket             | 1        |
| 46       |          | Bolt               | 1        |
| 51       |          | Washer             | 1        |
| 60       |          | Chain Stripper     | 1        |

6051019

6051022

6051043

## 2. SPECIFICATION

### 2.1 Gipsy Suitability

The patented rope/chain gipsy enables the windlass to be used for hauling rope and chain without the need to transfer from warping drum to gipsy. It is ideally suited to anchor rodes which consist of rope with a chain Rope used with rope/chain gipsies should be three strand nylon. The RCA60 gipsy is designed to suit 16 mm (5/8") rope, the RCA70 gipsy to suit 12 mm (1/2") rope but they all may accept diameters that are plus or minus 3 mm (1/8") depending on the particular lay of the rope. The A60 & A70 gipsies handle chain only.

Chain should be chosen to suit gipsies as follows:-

| GIPSY                 | CHAIN                    |                     |        |
|-----------------------|--------------------------|---------------------|--------|
| RCA60                 | S-L 0058004              | 9.5 mm              |        |
|                       | American Proof Coil      | 1/4"                |        |
|                       | American Proof Coil      | 5/16"               |        |
|                       | American BBB             | 5/16"               |        |
|                       | American BBB             | 3/8"                |        |
|                       | American Hi Test         | 5/16"               |        |
|                       | American Hi Test         | 3/8"                |        |
|                       | Australian PWB & Beavers | 10 mm               |        |
|                       | French NFE 26011         | 10 mm               |        |
|                       | German DIN 766 (1954)    | 8 mm                |        |
| RCA70                 | S-L 0058002              | 1/4"                |        |
|                       | S-L 0058003              | 8 mm                |        |
|                       | American BBB             | 1/4"                |        |
|                       | American Hi Test         | 1/4"                |        |
|                       | Australian PWB & Beavers | 8 mm                |        |
|                       | French NFE 26011         | 8 mm                |        |
|                       | German DIN 766 (1954)    | 7 mm                |        |
|                       | A60                      | S-L 0058004         | 9.5 mm |
|                       |                          | American Proof Coil | 1/4"   |
|                       |                          | American Proof Coil | 5/16"  |
| American BBB          |                          | 5/16"               |        |
| American BBB          |                          | 3/8"                |        |
| American Hi Test      |                          | 5/16"               |        |
| French NFE 26011      |                          | 8 mm                |        |
| German DIN 766 (1954) |                          | 8 mm                |        |
| Norwegian Ofobat      |                          | 1/4"                |        |
| Norwegian Ofobat      |                          | 5/16"               |        |
| A70                   | S-L 0058002              | 1/4"                |        |
|                       | S-L 0058003              | 8 mm                |        |
|                       | American BBB             | 1/4"                |        |
|                       | American Hi Test         | 1/4"                |        |
|                       | Australian PWB & Beavers | 8 mm                |        |
|                       | German DIN 766 (1954)    | 7 mm                |        |
|                       | Norwegian Ofobat         | 8 mm                |        |
|                       | Swedish                  | 5/16"               |        |

Depending on manufacture, other chains in the range from 6mm to 10mm and 1/4" to 3/8" may be suitable with one of the above gipsies. Should you have difficulty in matching a gipsy to your chain please consult your local agent or Simpson-Lawrence Limited.

### 2.2 Performance

Mechanical Advantage 12:1

### 2.3 Materials

Gipsy See 1.2.1  
 Drum See 1.2.1  
 Shaft Zinc Plated Steel  
 Case Aluminium alloy BS1490 LM6  
 Weight 11.4kg (25lb)

### 2.4 Package Contents

Operating Handle  
 4 Headed Bushes  
 Instruction Booklet  
 Chain Stripper, (Rope/chain Gipsy versions only)

## 3. ACCESSORIES & SPARES KITS

| List Number | Item               | Consisting of:   |
|-------------|--------------------|--|
| 0051005     | Windlass Cover     |  |
| 6051007     | Mainshaft Assembly | 1 x Item 4<br>1 x Item 7<br>1 x Item 25<br>1 x Item 26<br>1 x Item 28<br>1 x Item 33 |
| 6051020     | Handle             | 1 x Item 20<br>1 x Item 21   |
| 6051024     | Chain              | 1 x Item 23<br>1 x Item 24   |
| 6051099     | Seal Set           | 1 x Item 25<br>1 x Item 26<br>1 x Item 27<br>1 x Item 45                             |

## 4. PLANNING THE INSTALLATION

### 4.1 Additional Requirements

Each windlass installation requires:

- The following tools:
  - 6.5mm (1/4") Diameter Drill
  - 11mm (7/16") Diameter Drill
  - Jig Saw or Trepanning Tool
  - 13mm Spanner
- Sealant or Bedding Compound
- Automotive Gearbox Oil (SAE Grade EP80)

## 5. INSTALLATION

### 5.1 Fitting Windlass to Deck

- Ideally, the rode should lead forwards and downwards from the gipsy to the stemhead roller to ensure the best operation of the gipsy.
- Place the Windlass on the deck in the approximate position and check that the rode will line up correctly with the stemhead roller and that the chain pipe will lead the rode into the locker below.
- When a satisfactory position has been found, mark the position of the mounting bolt holes and the chain pipe hole on the deck.
- Rope/chain gipsy models must be fitted with the supplied stripper, item 60. It should be positioned just forwards of the rim of the chain pipe, with the single hole towards the bow and with the fin projecting up between the rope gripping serrations.
- Ensure that the gipsy does not foul the stripper when the clutch is released and mark the stripper's position when satisfied it is correct.
- Remove the windlass from the deck and bore four 11mm (7/16") diameter holes for its mounting bolts. Cut out the outline of the chain pipe hole. If applicable drill three 6.5mm (1/4") holes for the stripper.
- Apply bedding compound around the bottom face of the base of the windlass and any stripper. **NB** If using silicone or other rubbery type sealants, it is advisable to allow curing of the sealant before final tightening of the mounting bolts.
- Carefully place the windlass in position on the deck.
- Place the four supplied nylon bushes in position in the windlass' mounting holes, flanged end up.
- Fix the windlass to the deck with 9.5mm (3/8") diameter bolts, preferably of stainless steel but heavy duty galvanised bolts are suitable. Fix the stripper with similar 6mm bolts.
- Fill the windlass case to the height of the filling hole on the port side with EP80 gear oil. Ensure the filler cap, item 19, is replaced tightly using a 13mm spanner to prevent the oil from leaking.

### 5.2 JOINING ROPE TO CHAIN

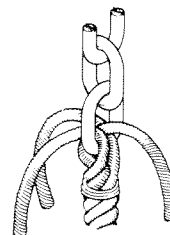

- With whipping twine or similar, seize your rope 300 mm (12") from the rope's end and unlay strands.
- Pass one strand through the chain end link from one side and other two strands from the opposite side.
- Remove seizing and complete back splice in normal manner for two full tucks.
- With a hot knife pare down the three strands by one third and continue with two further tucks.

5.2.5 Pare strands down by another third and finish with another two tucks.

5.2.6 Cut away remaining tails.  
This method of joining is designed to minimise chafe between rope and chain but as a matter of prudent seamanship it should be checked regularly and remade if there is any evidence of wear.

The rope chain gipsy is not a self tailing device, therefore rope, of the correct size, will require to be tailed sufficiently taught to allow it to grip in the rope channel.

Because of wide variations in rope type and construction some experimentation may be required.

## 6. OPERATING INSTRUCTIONS

### 6.1 Safety First

Ensure that fingers and loose clothing are kept clear of the rode and gipsy whilst they are in motion to avoid personal injury! Also, always ensure that there are no swimmers nearby before lowering your anchor.

### 6.2 Function of Clutch

6.2.1 The clutch engages and disengages the gipsy from the windlass drive. The clutch nut, item 6, is designed for use with the supplied operating handle, item 20.

6.2.2 The clutch is disengaged by inserting the handle into the clutch nut and by pulling the handle aft. Re-engage the clutch by pushing the handle forwards.

### 6.3 Function of Gipsy Pawl

The gipsy pawl, item 5, swivels in and out of engagement. It has been designed such that when engaged in the gipsy, clockwise rotation of the gipsy is resisted.

### 6.4 Anchor Release

6.4.1 To let go, disengage the gipsy pawl and insert the operating handle in the clutch nut.

6.4.2 Release the clutch by pulling the handle aft. Pushing the handle forwards re-engages the clutch, giving a breaking action which controls the speed at which rode runs out under gravity.

6.4.3 When sufficient chain has been let out, fully tighten the clutch and re-engage the gipsy pawl.

### 6.5 Lying to Anchor Safely

6.5.1 Boats lying to their anchor in a high swell or heavy weather conditions will snub on the anchor or mooring rope and this can cause the rode to slip or apply excessive loads to the windlass.

6.5.2 For maximum safety the windlass must not be left to take the entire force from the anchor rode and a bridle should be used to transfer the load to a mooring cleat or bollard. Alternatively, the rode can be removed from the windlass gipsy and made fast directly to a bollard or sampson post.

### 6.6 Hauling In

6.6.1 Insert the handle into the operating spindle, item 8 and disengage the gipsy pawl.

6.6.2 Move the handle back and forth.

### 6.7 Warping

6.7.1 If the gipsy is in use, ensure that the gipsy pawl is engaged.

6.7.2 Slacken the clutch nut to disengage the gipsy clutch.

6.7.3 The warping drum can now be made to revolve independently of the gipsy when hauling in in the normal manner.

6.7.4 Rope/drum slippage can normally be overcome by increasing the number of turns of rope taken on the drum. Take at least three turns of rope around the drum while tailing the free end.

6.7.5 Letting out of the rope is achieved by gently easing the turns on the drum.

### 6.8 Operating Tips

6.8.1 When anchoring, it is best to allow the rode to run out slowly, allowing the vessel to take up sternway before full scope is let out. This helps prevent the rode from becoming tangled on top of your anchor on the sea bed.

6.8.2 To aid anchor recovery, we recommend that the vessel's engine be used to assist by moving the vessel towards the anchor. We do not recommend that the vessel is motored over and beyond the anchor, as this can cause the rode to damage your topsides.

6.8.3 When mooring stern to, at a suitable distance from the jetty, deploy the anchor to prevent the bows from swinging. Gently pay out the rode under the influence of the stern way of the vessel. By stopping the windlass, the anchor can be used to restrain the vessel as it approaches the jetty. Make fast your vessel with warps from the stern.

## 7. IMPORTANT USER INFORMATION

Classification Societies require that a vessel lying to anchor should have its rode held by a chain stopper or equivalent strong point as windlasses are not designed to withstand the loads generated under storm conditions. This rule should be applied to all craft!

Whilst under way it is the responsibility of the boat user to ensure that the anchor and rode are properly stowed for the prevailing sea conditions. This is particularly important with high speed power boats.

An anchor windlass is mounted in the most exposed position on a vessel and is thus subject to severe atmospheric attack resulting in a possibility of corrosion in excess of that experienced with most other items of deck equipment. As the windlass may only be used infrequently, the risk of corrosion is further increased. When the windlass is mounted in an anchor well with a closing lid, due to lack of ventilation and consequent high saline conditions the rate of corrosion is accelerated. It is essential that the windlass is regularly examined, operated and given any necessary maintenance. This is of even greater importance when the windlass is installed in an anchor well!

## 8. MAINTENANCE

### 8.1 General Recommendations

After the first two or three anchor recoveries, check that the windlass is still fastened tightly to your deck as it should now be 'bedded-in'.

Regularly wash down the exterior of your windlass with fresh water.

Regularly lubricate the mainshaft grease nipple, item 33, with Shell Alvania or similar grease.

Occasionally check the oil level in the windlass case and operate the windlass to circulate the lubricant.

Occasionally apply a few drops of oil to external moving parts. For smoothest operation of the clutch ensure that the clutch cone and its seat on the side of the gipsy are kept free from excess salt deposits.

### 8.2 Winter Laying Up

When laying up, the gipsy can be removed from the mainshaft and grease smeared into its bore. The mainshaft and gipsy cone should also be coated with grease.

Given correct installation and maintenance your windlass will require little attention prior to, or after, winter lay up. Check between the windlass deck housing and deck for signs of water ingress. Should it occur, remove, clean and reseal the deck plate.

## 9. WARRANTY

The Simpson-Lawrence warranty covers your unit for a period of one year from the date of purchase, to be free from defects in material and workmanship. This warranty is subject to proper installation and use in service as described in this booklet. Our current catalogue contains our full "Conditions of Sale". A copy of these conditions can be obtained by application to any of our branches or our agents.

The models described in this document are subject to a policy of continual improvement. Simpson-Lawrence Ltd. reserve the right to alter specifications and recommendations without notice. For the latest information regarding any aspect of your windlass please contact your local agent or:-

### Simpson-Lawrence Limited,

218/228 Edmiston Drive, Glasgow, G512YT, United Kingdom.

Telephone No. Domestic: 0141-427-5331/8  
International: Code+44-141-427-5331/8

Fax No. Domestic: 0141-427-5419  
International: Code+44-141-427-5419

### Simpson Lawrence USA Inc.,

6208, 28th Street East, Bradenton, Florida, 34203-4123, United States of America.

Telephone # Domestic: <sup>941</sup>~~813~~-753-7533  
International: Code+1-813-753-7533

Fax # Domestic: 813-746-7166  
International: Code+1-813-746-7166